



HTB1-S
Home Theater Loudspeaker
System



1 Mitek Plaza
Winslow, IL 61089
815-367-3000
800-225-5689

INTRODUCTION

Congratulations on your purchase of MTX Loudspeakers. Your new speakers represent the latest technologies in loudspeaker design and manufacturing. They will provide outstanding performance and years of listening enjoyment. Please take time to read through this manual thoroughly to insure you get maximum performance out of your new loudspeakers.

SATELLITE/CENTER CHANNEL FEATURES

- Video shielding for placement near a TV or monitor
- 1/2" Balanced dome tweeter
- Spring loaded push terminals
- Injection molded plastic cabinets

SUBWOOFER FEATURES

- High efficiency amplifier
- Bass reflex enclosure with low noise vent
- Adjustable low-pass crossover frequency
- Adjustable gain control

SPEAKER PLACEMENT

HTB1 SET UP GUIDE

Typical Loudspeaker Placement

Figure 1 illustrates the most generally accepted speaker locations for a home theater system. Although there are an infinite number of set up options using **Figure 1** as a template will certainly provide a great starting point. Experimentation with slightly different speaker locations may provide improved performance in your specific listening environment.

The front left and right speakers should form a 45 degree triangle using the center seating position as the apex.

The surround speakers should be placed beside the listening area, and pointed towards each other. It is also recommended that the speakers be 2-3 feet above the listeners head.

Left/Center/Right Front Speaker Height

One of the most important parameters for the left/center/right front speakers in a home theater system is height. **Figure 2** shows the ideal arrangement of the speakers in relation to the viewing screen: all three speakers are aligned on the same horizontal plane. This establishes a firm image height when special audio effects are panned from one side to the other, such as a speeding car moving across the screen. When a large discontinuity occurs between the heights of the center front channel and the left/right front speakers, as depicted in **Figure 3**, the image of the moving object becomes confused and somewhat unnatural due to shifts in image height.

CARE AND MAINTENANCE

Your speakers are designed to work with a wide range of electronic components. As little as 20 watts per channel can provide enough power for most applications. If you have a large room or prefer louder listening levels, more power may be required.

Caution: When choosing an amplifier, do not exceed the power rating of the speaker. If you hear very high levels of audible distortion you are exceeding the capabilities of the system. Damage can occur from this distortion, turn the volume back down until the distortion disappears.

Use the following guidelines to maintain the appearance of your speakers. Use a soft, damp cloth to clean the speaker cabinet. Avoid using harsh detergents or cleaning fluids. Remove the grills to vacuum and remove dust. Do not vacuum any of the speaker components, permanent damage could occur.

TECHNICAL ASSISTANCE

For additional technical assistance you can visit our website at mtx.com. Otherwise, our technical service representatives can be reached by phone: 1-800-CALLMTX (1-800-225-5689) or by email: technical@mtx.com.

MTX WARRANTY INFORMATION

All HTB1 speaker systems purchased in the United States from an authorized MTX dealer are guaranteed against defects in material and workmanship for a period of ONE YEAR from the date purchased by the end user, and limited to the original retail purchaser of the product. Product found to be defective during that period will be repaired or replaced by MTX at no charge. This warranty is void if it is determined that unauthorized parties have attempted repairs or alterations of any nature. Warranty does not extend to cosmetics or finish. Before presuming a defect is present in the product, be certain that all related equipment and wiring is functioning properly. MTX disclaims any liability for other incurred damages resulting from product defects. Any expenses incurred in the removal and reinstallation of product is not covered by this warranty. MTX's total liability will not exceed the purchase price of the product. If a defect is present, your authorized MTX dealer may be able to effect repairs.

Proof of purchase is required when requesting service, so please retain your sales receipt and take a moment to register your product on line mtx.com.

SPECIFICATIONS

HTB1 Satellite/Center Channel

Driver Complement

Midrange- 3" shielded with paper cone, foam surround

Tweeter- 1/2" Balanced dome tweeter

Frequency Response: 150Hz - 20kHz

Impedance: 8 ohms nominal

Power Handling: 75 watts RMS / 150 watts peak music

Recommended Amplifier Power: 20-100 watts RMS

Sensitivity: 85dB@2.83V/1M

Weight:

Satellite- 1.8 lbs.

Center Channel- 3.0 lbs

Dimensions:

Satellite- 6"H X 4 1/8"W X 4 1/8"D

Center Channel- 4 1/8"H X 9 11/16"W X 3 7/8"D

HTB1 Subwoofer

Driver Complement

Woofer- 8" high excursion woofer

Amplifier Power: 120W Peak Music Power

Crossover Frequency: continuously variable 50Hz-150Hz

Frequency Response: 50Hz - 150Hz

Enclosure: tuned port design

Weight: 16.5 lbs.

Dimensions: 13 3/4" H X 10" W X 13 3/16" D

Optional Installation Accessories

A. Feet for Satellites

Included in the system are rubber feet that allow you to raise the Satellite Speakers up off of a level surface. Simply peel each of the four feet off the sheet and press on to the bottom of the Satellite Speaker. Repeat steps for the remaining Satellite Speakers.

B. Feet for Center Channel

Included in the system are plastic feet that allow the Center Channel to be angled more horizontally on top of your television monitor. If you wish to use the feet, simply insert the knurled end of the feet into the two holes in the lower rear of the Center Channel.

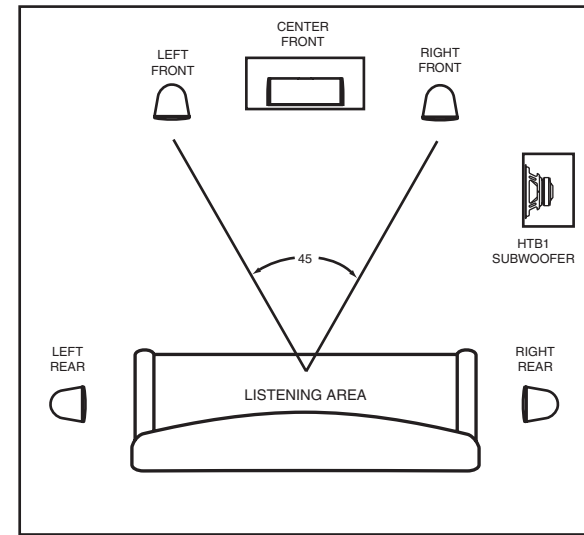

Figure 1- Typical loudspeaker placement in a home theater system.

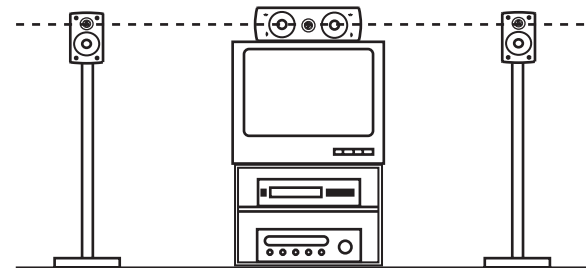

Figure 2- Proper placement of left/center/right front speakers.

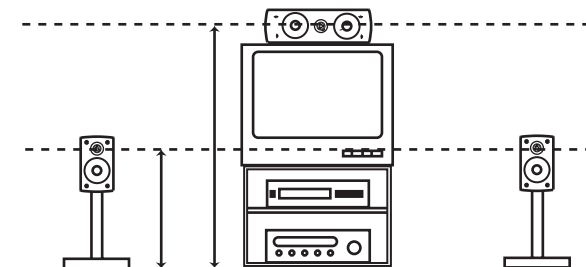

Figure 3- Improper placement of left/center/right front speakers.

EXPLANATION OF FEATURES AND CONTROLS

Refer to Figure A

1) Power Switch: This two position switch controls the power status of the subwoofer.

Off: Turns the unit off.

On: Turns the unit on regardless of whether a signal is present or not.

2) Subwoofer crossover (Freq): This rotary control adjusts a variable low pass filter to set the upper frequency at which the output of the subwoofer begins to roll-off. Continuously variable from 50Hz to 150 Hz, it matches the upper frequency characteristics of the subwoofer to the low frequency response of the main stereo speakers. **Recommended setting: 120Hz-150Hz.**

3) Line level input: These RCA phono jacks accept a line level full range signal from the preamplifier output of a receiver or preamplifier. This full range signal is processed and amplified to power the subwoofer.

4) Speaker level (high level) input: These spring loaded terminals for speaker wire accept a stereo, speaker level, full range signal from a receiver or power amplifier. This signal is processed and amplified to power the subwoofer.

5) Fuse: For continued protection replace fuse with same type and size listed.

6) Level control (Gain): This rotary control adjusts the level of the subwoofer and is used to balance its volume with that of the main stereo speakers.

7) Status LED: This light emitting diode shows the status of the subwoofer electronics. "Red" indicates that the amplifier is plugged in and the power switch is on.

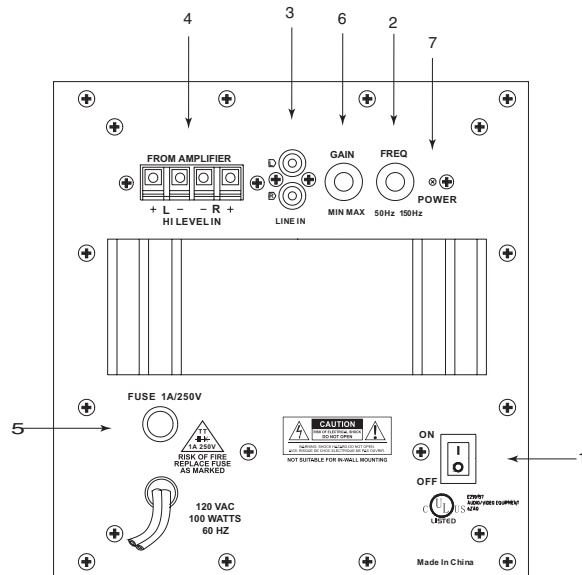

FIGURE A

WIRING AND CONNECTIONS

Turn off all power to your subwoofer and other equipment before making any connections.

Installation using speaker level inputs (Figure B).

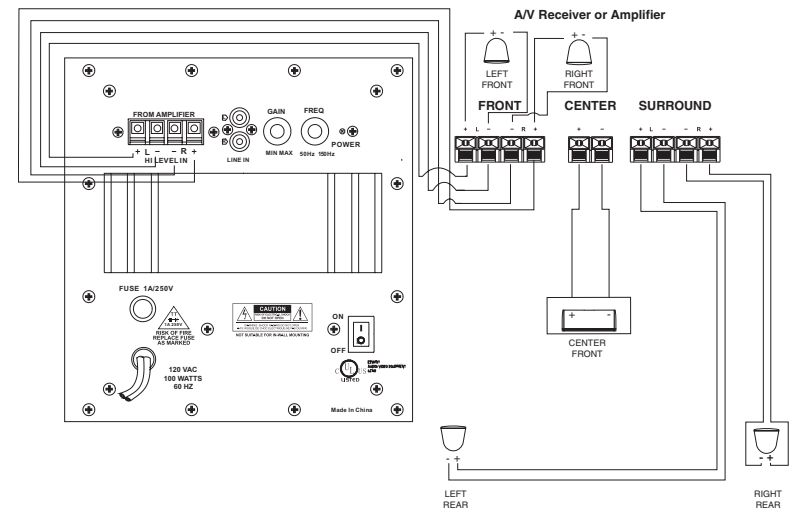

FIGURE B

Installation with A/V amplifiers and receivers that have 5.1 channel line level output (Figure C).

Use an RCA "Y" adaptor to connect both line level inputs.

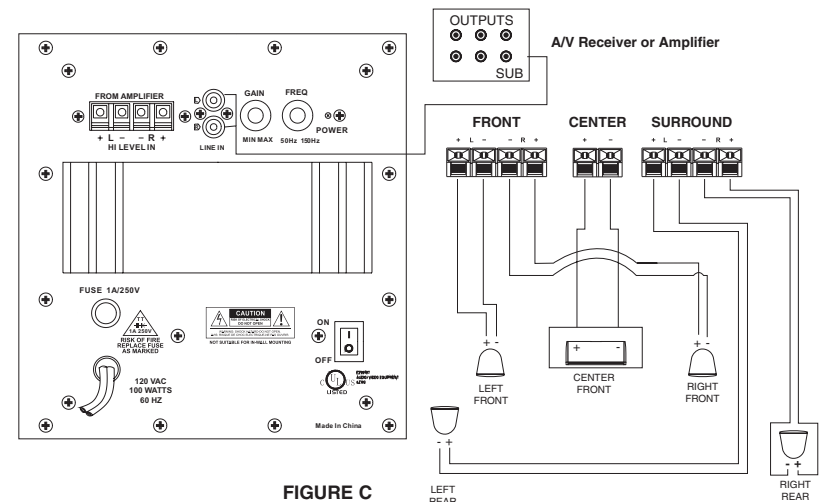

FIGURE C